

# PROCESS & TEMPERATURE CONTROLLER

**MULTISPAN**

**PTC- 1202**



PV = Process value  
SV = Set Value

## TECHNICAL SPECIFICATION

### INPUT SPECIFICATION:

Input Types	Input	Range
	J	0 to 600 °C
	K	0 to 1200 °C
	PT-100	-99 to 400 °C
	PT.1	-99.9 to 400.0 °C
	0-10V DC	-1999 to 9999
	0-20mA DC	-1999 to 9999
4-20mA DC	-1999 to 9999	
Resolution	J,K,PT-100 = 1 °C	
	PT.1 = 0.1 °C	
	0-10V DC,0-20mA DC,4-20mA DC = 0.1,0.01,0.001,0001	
Indication Accuracy	±1% of FSD ± 1 Count (FSD : full scale deflection)	

### DISPLAY AND KEYS:

Display	Upper : 4 digit,7 seg 0.8" RED LED Lower : 4 digit,7 seg 0.56" White LED
Keys	SET, INC, DEC, ENT

### DIMENSION:

Size	101 (H) x 101 (W) x 54 (D) mm
Panel Cutout	92 (H) x 92 (W) mm

### CONTROL METHOD:

Heating	1) PID control with Auto-Tuning 2) ON-OFF control
Cooling	1) BL.TP (Blower Time Proportion) 2) ON-OFF control
Alarm	High/Low/Inband/Outband/ Absolute Low/Absolute Outband

## OUTPUT SPECIFICATION

Relay Output	
Relay	2 nos.
Relay Type	1 C/O (NO-C-NC)
Rating	5A, 230V AC/30 V DC
Transmitter supply	
24V DC	

## AUXILIARY SUPPLY

Supply voltage	100 to 270V AC, 50-60Hz
Power consumption (VA RATING)	Approx 7 VA @ 230V AC MAX

## ENVIRONMENT CONDITION

Operating Temp.	0 °C to 55 °C
Relative Humidity	UP to 95% RH (non-condensing)
Protection Level	IP-65 (Front side) As per IS/IEC 60529 : 2001

## MECHANICAL INSTALLATION

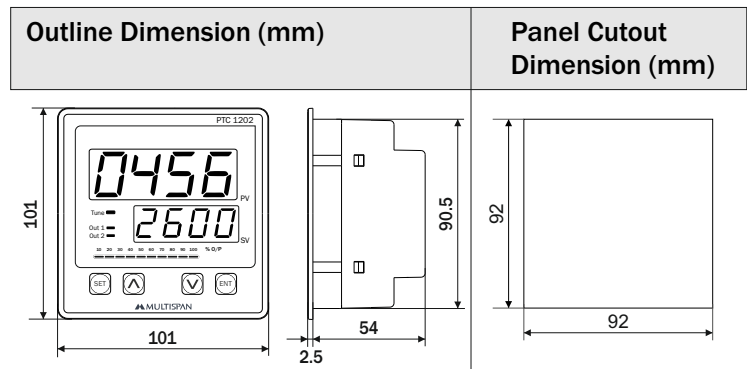

## TERMINAL CONNECTION

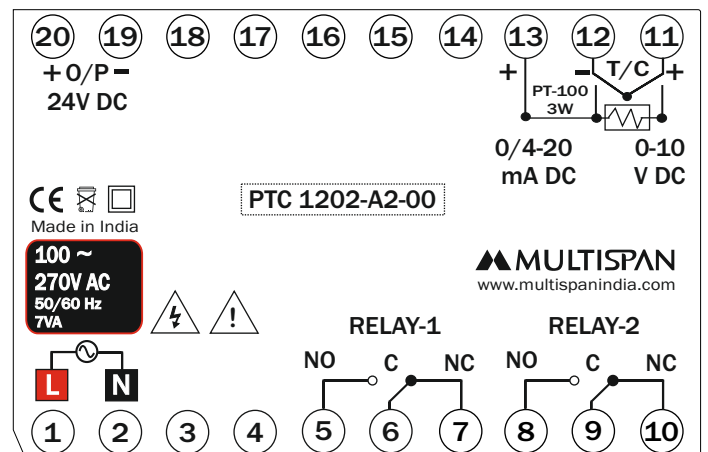

## DISPLAY INDICATION

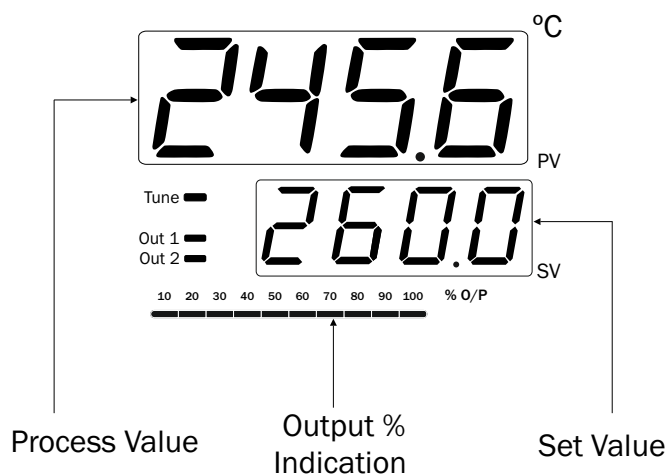

## KEY OPERATION

FUNCTION	PRESS KEY
<b>OPERATOR MODE</b>	
To enter in parameter setting	Press for 5 sec
For start/stop PID auto tuning	Press 6 sec
To go in factory setting mode	+  Press 3 sec
To Reset soak process	Long Press
<b>PARAMETER SETTING MODE</b>	
To set parameter value	
To increment parameter value.	
To decrement parameter value.	
Set parameter to be save & exit.	



## SAFETY PRECAUTION

All safety related codifications, symbols and instructions that appears in this operating manual or on the equipment must be strictly followed to ensure the safety of the operating personnel as well as the instrument.

If all the equipment is not handled in a manner specified by the manufacturer, it might impair the protection provided by the equipment.



Read complete instructions prior to installation and operation of the unit.



**WARNING : Risk of electric shock.**

## MECHANICAL INSTALLATION GUIDELINES

1. Prepare the panel cutout with proper dimensions as shown above.
2. Fit the unit into the panel with the help of clamp given.
3. The equipment in its installed state must not come in close proximity to any heating source, caustic vapors, oils steam, or other unwanted process byproducts.
4. Use the specified size of crimp terminal (M3.5 screws) to wire the terminal block. Tightening the screws on the terminal block using the tightening torque of the range of 1.2 N.m.
5. Do not connect anything to unused terminals.

## MAINTENANCE

1. The equipment should be cleaned regularly to avoid blockage of ventilating parts.
2. Clean the equipment with a clean soft cloth. Do not use isopropyl alcohol or any other cleaning agent.
3. Fusible resistor must not be replaced by operator.

## INSTALLATION GUIDELINES

1. This equipment, being built-in-type, normally becomes a part of main control panel and in such cases the terminals do not remain accessible to the end user after installation and internal wiring.
2. Do not allow pieces of metal, wire clippings, or fine metallic fillings from installation to enter the product or else it may lead to a safety hazard that may in turn endanger life or cause electrical shock to the operator.
3. Circuit breaker or mains switch must be installed between power source and supply terminal to facilitate power 'ON' or 'OFF' function. However this mains switch or circuit breaker must be installed at convenient place normally accessible to the operator.
4. Use and store the instrument within the specified ambient temperature and humidity ranges as mentioned in this manual.

## WARNING GUIDELINES



**WARNING : Risk of electric shock.**

1. To prevent the risk of electric shock, power supply to the equipment must be kept OFF while doing the wiring arrangement. Do not touch the terminals while power is being supplied.
2. To reduce electro magnetic interference, use wire with adequate rating and twists of the same of equal size shall be made with shortest connection.
3. Cable used for connection to power source, must have a cross section of 1mm or greater. These wires should have insulations capacity made of at least 1.5kV.
4. When extending the thermocouple lead wires, always use thermocouple compensation wires for wiring for the RTD type, use a wiring material with a small lead resistance (5Ω max per line) and no resistance differentials among three wires should be present.
5. A better anti-noise effect can be expected by using standard power supply cable for the instrument.

## FACTORY SETTING

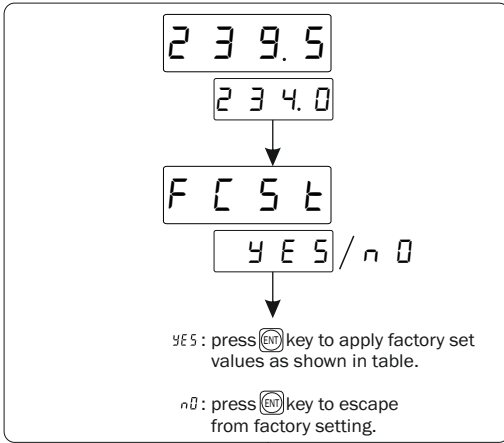

FACTORY SETTING		
SR.	PARAMETER	VALUES
1	PB	20.0° C
2	IT	300
3	DT	75
4	CT	15 sec
5	MR	0°C
6	OFFSET	0°C
7	HYSTERESIS-1	3°C
8	HYSTERESIS-2	3°C
9	C-PB	4.0° C
10	C-ON	1 Sec
11	C-OFF	48 Sec
12	CRFC	0

## PARAMETER MESSAGE DESCRIPTION

C.SET	Controlling O/P Set Point
SEt1	Set Point 1 For O/P 1
SEt2	Set Point 2 For O/P 2
LOw1	Low Set Point 1
HIG1	High Set Point 1
LOw2	Low Set Point 2
HIG2	High Set Point 2
PA55	Password
INPt	Input ( Sensor )
SLL	Set Low Limit
SHL	Set High Limit
OFFt	Offset
Pb	Proportional Band For PID Action
It	Integral Time Constant
dIt	Derivative Time Constant
Ct	Cycle Time For PID Action
r	Manual Reset
C-Pb	Cooling PB
C-On	Cooling On Time
C-OF	Cooling Off Time
HYS1	Hysteresis 1

## PARAMETER MESSAGE DESCRIPTION

HYS2	Hysteresis 2
OUT1	OutPut 1 Mode
SOAK	Soak Time Select
SOAK	Soak Mode
SOAK	Soak Unit
SOAK	Soak Time Value
SOAK	Soak Time Memory
SOAK	Soak Time End
Ctrl1	Control Action 1
OUT2	Output 2 Mode
Ctrl2	Control Action 2
AL1	Alarm 1
AL2	Alarm 2
Set2	Set 2 Mode
r1dL	Relay 1 Delay Time
r2dL	Relay 2 Delay Time
ALt	Alarm Time
PID	PID Action
ONOFF	ON-OFF Action
bl.tP	Blower TP Action
HIGH	High Alarm
LOW	Low Alarm
Out-b	OutBand Alarm
Ab-L	Absolute Low Alarm
In-b	In Band Alarm
Ab-O	Absolute Out Band Alarm
SEC	Second
min	Minute
HOUR	Hour
HEAT	Heating Mode
COOL	Cooling Mode
ALr	Alarming Mode
OFF	OFF Mode
YES	Yes
n0	No
SAVE	Save
Ind1	Set 2 Individual to Set 1
rLt	Set 2 Reletive to Set 1
FCS	Factory Setting

## PARAMETER MESSAGE DESCRIPTION

LOWP	Low percentage
HIP	High percentage
FRWD	Forward
REVR	Reverse
LRNG	Low Range for analog input
HRNG	High Range for analog input
CRFC	Correction Factor for analog input
FLTR	Filter Time
SLL	Signal Low Limit for 4-20mA input
RLY1	Relay 1 parameter setting
RLY2	Relay 2 parameter setting

SPPS	Soak Passing
SPRG	Soak Remaining
SPEN	Soak Time Normal
AUTO	Auto

## RANGE FOR CONTROL PARAMETER

SR.	PARAMETER	RANGE FOR J,K,PT-100	RANGE FOR PT.1	RANGE FOR ANALOG INPUT	
1	PB	0.0 to 999.9 °C	0.0 to 999.9 °C	0.0 to 999.9	
2	IT	0 to 9999	0 to 9999	0 to 9999	
3	DT	0 to 9999	0 to 9999	0 to 9999	
4	CT	4 to 99 sec	4 to 99 sec	4 to 99 sec	
5	MR	-9 to 9 °C	-9.0 to 9.0 °C	DP 3	-0.099 to 0.099
				DP 2	-0.99 to 0.99
				DP 1	-9.9 to 9.9
				DP 0	-99 to 99
6	OFFSET	-20 to 20 °C	-20.0 to +20.0 °C	DP 3	-0.999 to 0.999
				DP 2	-9.99 to 9.99
				DP 1	-99.9 to 99.9
				DP 0	-999 to 999
7	HYS1	1 to 100 °C	0.1 to 100.0 °C	DP 3	0.001 to 0.999
				DP 2	0.01 to 9.99
				DP 1	0.1 to 99.9
				DP 0	1 to 999
8	HYS2	1 to 100 °C	0.1 to 100.0 °C	DP 3	0.001 to 0.999
				DP 2	0.01 to 9.99
				DP 1	0.1 to 99.9
				DP 0	1 to 999
9	C-PB	2.0 to 25.0 °C	2.0 to 25.0 °C	2.0 to 25.0	
10	C-ON	1 to 20 sec	1 to 20 sec	1 to 20 sec	
11	C-OF	5 to 200 sec	5 to 200 sec	5 to 200 sec	
12	R1DL	0.00 to 99.59 mm.ss	0.0 to 99.59 mm.ss	0.00 to 99.59 mm.ss	
13	R2DL	0.00 to 99.59 mm.ss	0.0 to 99.59 mm.ss	0.00 to 99.59 mm.ss	
14	ALTM	0 to 99 sec	0 to 99 sec	0 to 99 sec	
15	CRFC	-	-	DP 3	-0.999 to 0.999
				DP 2	-9.99 to 9.99
				DP 1	-99.9 to 99.9
				DP 0	-999 to 999
16	FLTR	-	-	0.1 to 10.0 Sec	
17	SLL	-	-	0.0 to 5.0 mA	

# PARAMETER SETTING

## Password 73 Explanation

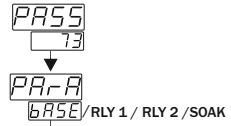

- Parameter 1 : Basic Configuration (bRSE)
- Parameter 2 : Relay 1 (rLY1)
  - Case 1 : Heat
  - Case 2 : Cool
  - Case 3 : Alarm
  - Case 4 : Off
- Parameter 3 : Relay 2 (rLY2)
  - Case 5 : Heat
  - Case 6 : Cool
  - Case 7 : Alarm
  - Case 8 : Off
- Parameter 4 : Soak Timer (SOAK)

Note : In case 4 & 8 relay will be in off condition

### Case 4 & 8 : OFF



## Parameter 1 : Basic Configuration (bRSE)

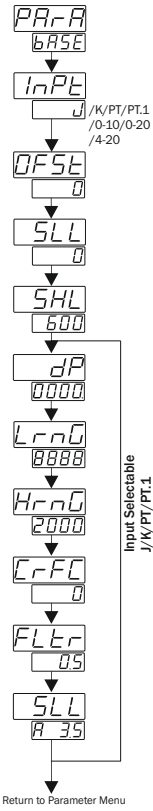

## Parameter 2 : Relay 1 (rLY1)

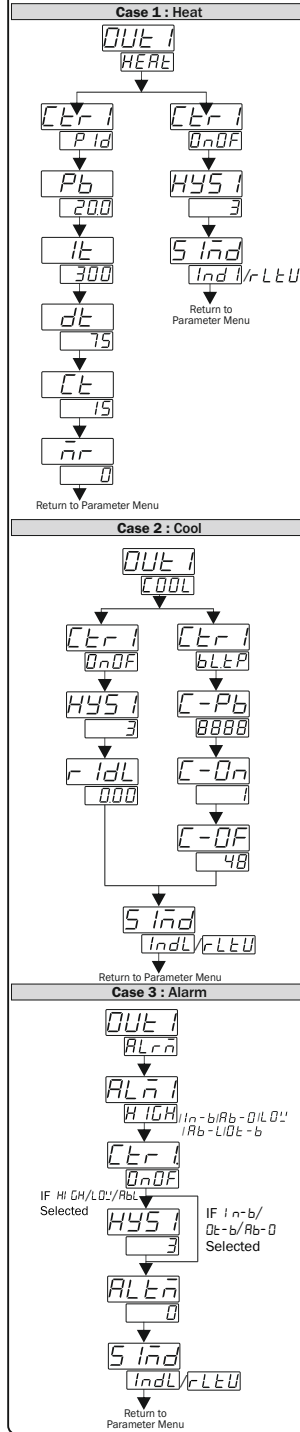

## Parameter 3 : Relay 2 (rLY2)

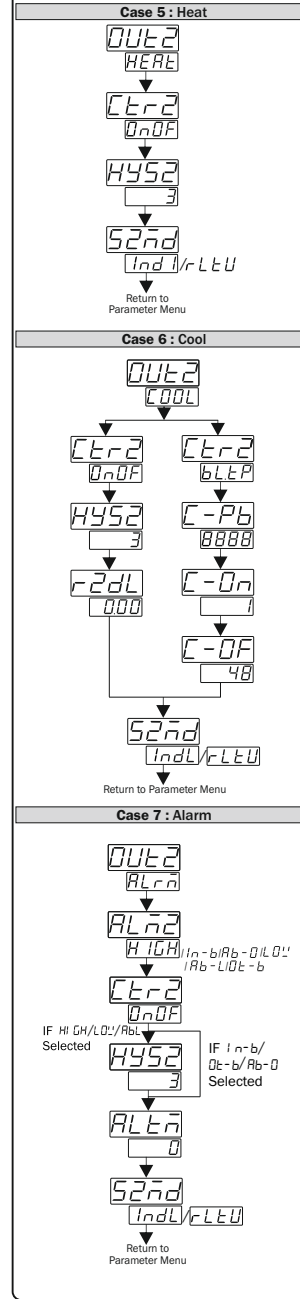

## Parameter 4 : Soak Timer (SOAK)

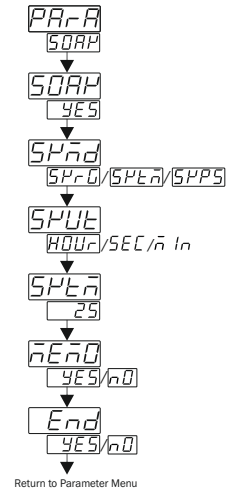

# CONTROL FUNCTION

